

Network Protocol For Nets Scale

TCP/IP Information.		
	Name	Default Value
1	IP Address	211.171.137.40
2	Sub Net Mask	255.255.255.192
3	Gateway	211.171.137.1
4	Port Address	5000 (Default)

Check Sum
The result value after processing data with the Exclusive-OR command. ex) data = "12345", Check sum (data type : unsigned char) = 0 Check sum = check sum ^ 31h. Check sum = check sum ^ 32h. Check sum = check sum ^ 33h. Check sum = check sum ^ 34h. Check sum = check sum ^ 35h. Check sum = 31h → 20h, 33h, 31h

- **Transmit Data (Server to Scale)**

1. PLU Data
2. Speed Key Data
3. Operator Data
4. Department Data
5. Store Name Data
6. Sales Message
7. Price Change
8. Not PLU
9. ALL Memory Clear
10. One PLU Clear
11. Label Data
12. Receive PLU Data
13. Close Sock

- **Receive Data (Scale to Server)**

1. PLU Data
2. Sales Data information

- 3. PLU transmission request
- 4. Modify Price transmission
- 5. Returned sale information

**ENQ = 0x05, ACK = 0x06, EOT = 0x04, STX = 0x02,
ETX = 0x03, NAK = 0x15, CR = 0x0D**

Transmit Data (Server to Scale)

1. PLU Data

P.C	<p>ENQ (0x05) →</p> <p style="text-align: right;">← ACK (0x06)</p> <p>STX (0x02) →</p> <p>Data Length (3Bytes) → (*)</p> <p>Send ID →</p> <table border="1" style="margin-left: auto; margin-right: auto;"> <tr> <td style="padding: 2px;">0x30</td> <td style="padding: 2px;">0x32</td> </tr> </table> <p>Network Department Code (2 Bytes) →</p> <p>Group Code (2 Bytes) →</p> <p>PLU No (8 Bytes) →</p> <p>Unit Price (8 Bytes) →</p> <p>Item Code (6 Bytes) →</p> <p>Cook By Date (3 Bytes) →</p> <p>Shelf Life (3 Bytes) →</p> <p>Native Code (3 Bytes) →</p> <p>PLU Tare (5 Byte) →</p> <p>PLU Type (1 Bytes) →</p> <p>Title Code (1 Bytes) →</p> <p>Commodity Name-1 (28 Bytes Char) →</p> <p>Commodity Name-2 (28 Bytes Char) →</p> <p>Ingredient Line-1 (56 Bytes) →</p> <p>Ingredient Line-2 (56 Bytes) →</p> <p>Ingredient Line-3 (56 Bytes) →</p> <p>Ingredient Line-4 (56 Bytes) →</p> <p>Ingredient Line-5 (56 Bytes) →</p> <p>Ingredient Line-6 (56 Bytes) →</p> <p>Ingredient Line-7 (56 Bytes) →</p> <p>Ingredient Line-8 (56 Bytes) →</p> <p>Ingredient Line-9 (56 Bytes) →</p> <p>Ingredient Line-10 (56 Bytes) →</p> <p>Check Sum (3Bytes) →</p> <p>ETX (1Bytes) →</p> <p>CR (0x0d) →</p> <p>← ACK (0x06) OR NAK (0x15) OR EOT (0x04) OR EM (0x19)</p> <p>EOT (0x04)=End of Data →</p>	0x30	0x32	SCALE
0x30	0x32			

(*) Data length.

If PLU became input to commodity name 1st, data lengths are 70 Bytes.

Department Code (2 Bytes)	Group Code (2Bytes)	PLU No (8 Bytes)	Unit Price (8 Bytes)	...	PLU Type (1 Bytes)	Title Code (1 Bytes)
------------------------------	------------------------	---------------------	-------------------------	-----	-----------------------	-------------------------

Commodity Name-1 (28 Bytes)

If PLU became input to commodity name 2nd, data lengths are 98 Bytes.

Department Code (2 Bytes)	Group Code (2Bytes)	PLU No (8 Bytes)	Unit Price (8 Bytes)	...	PLU Type (1 Bytes)	Title Code (1 Bytes)
------------------------------	------------------------	---------------------	-------------------------	-----	-----------------------	-------------------------

Commodity Name1 (28 Bytes)	Commodity Name2 (28 Bytes)
----------------------------	----------------------------

If PLU became input to Ingredient 1st, data lengths are 154 Bytes.

Department Code (2 Bytes)	Group Code (2Bytes)	PLU No (8 Bytes)	Unit Price (8 Bytes)	...	PLU Type (1 Bytes)	Title Code (1 Bytes)
------------------------------	------------------------	---------------------	-------------------------	-----	-----------------------	-------------------------

Commodity Name1 (28 Bytes)	Commodity Name2 (28 Bytes)	Ingredient 1 st (56 Bytes)
-------------------------------	-------------------------------	--

...

If PLU became input to Ingredient 10th, data lengths are 658 Bytes.

Department Code (2 Bytes)	Group Code (2Bytes)	PLU No (8 Bytes)	Unit Price (8 Bytes)	...	PLU Type (1 Bytes)	Title Code (1 Bytes)
------------------------------	------------------------	---------------------	-------------------------	-----	-----------------------	-------------------------

Commodity Name1 (28 Bytes)	Commodity Name2 (28 Bytes)	Ingredient 1 st (56 Bytes)	...	Ingredient 10 th (56 Bytes)
-------------------------------	-------------------------------	--	-----	---

2. Speed Key Data

P.C	<p>ENQ (0x05) →</p> <p style="text-align: right;">← ACK (0x06)</p> <p>STX (0x02) →</p> <p>Data Length (3Bytes) →</p> <p>Send ID →</p> <table border="1" style="margin-left: auto; margin-right: auto;"> <tr> <td style="padding: 2px;">0x30</td> <td style="padding: 2px;">0x35</td> </tr> </table> <p>NO (1 Byte) →</p> <p>Speed Key No 1(5 Bytes) →</p> <p>Speed Key No 2(5 Bytes) →</p> <p>Speed Key No 3(5 Bytes) →</p> <p>Speed Key No 4(5 Bytes) →</p> <p>Speed Key No 5(5 Bytes) →</p> <p>Speed Key No 6(5 Bytes) →</p> <p>Speed Key No 7(5 Bytes) →</p> <p>Speed Key No 8(5 Bytes) →</p> <p>Speed Key No 9(5 Bytes) →</p> <p>Speed Key No 10(5 Bytes) →</p> <p>Check Sum (3Bytes) →</p> <p>ETX (0x03) →</p> <p>CR (0x0d) →</p> <p style="text-align: right;">← ACK (0x06) OR NAK (0x15)</p> <p>EOT (0x04)=End of Data →</p>	0x30	0x35	SCALE
0x30	0x35			

3. Operator Data

P.C	ENQ (0x05) →	SCALE		
			← ACK (0x06)	
	STX (0x02) →			
	Data Length (3Bytes) →			
	Send ID →			
	<table border="1" style="display: inline-table;"> <tr> <td style="padding: 2px;">0x31</td> <td style="padding: 2px;">0x30</td> </tr> </table>		0x31	0x30
	0x31		0x30	
	Operator No (2 Bytes) →			
	Operator Name (10 Bytes) →			
	Check Sum (3Bytes) →			
ETX (0x03) →				
CR (0x0d) →				
	← ACK (0x06) OR NAK (0x15)			
EOT (0x04)=End of Data →				

4. Department Data

P.C	ENQ (0x05) →	SCALE		
			← ACK (0x06)	
	STX (0x02) →			
	Data Length (3Bytes) →			
	Send ID →			
	<table border="1" style="display: inline-table;"> <tr> <td style="padding: 2px;">0x30</td> <td style="padding: 2px;">0x37</td> </tr> </table>		0x30	0x37
	0x30		0x37	
	Department No (2 Bytes) →			
	Department Name (20 Bytes) →			
	Check Sum (3Bytes) →			
ETX (0x03) →				
CR (0x0d) →				
	← ACK (0x06) OR NAK (0x15)			
EOT (0x04)=End of Data →				

5. Store Name Data

P.C	ENQ (0x05) →	SCALE		
			← ACK (0x06)	
	STX (0x02) →			
	Data Length (3Bytes) →			
	Send ID →			
	<table border="1" style="display: inline-table;"> <tr> <td style="padding: 2px;">0x30</td> <td style="padding: 2px;">0x36</td> </tr> </table>		0x30	0x36
	0x30		0x36	
	Store Name-1 (56 Bytes) →			
	Store Name-2 (56 Bytes) →			
	Check Sum (3Bytes) →			
ETX (0x03) →				
CR (0x0d) →				
	← ACK (0x06) OR NAK (0x15)			
EOT (0x04)=End of Data →				

6. Sales Message

P.C	ENQ (0x05) →	SCALE		
			← ACK (0x06)	
	STX (0x02) →			
	Data Length (3Bytes) →			
	Send ID →			
	<table border="1" style="display: inline-table;"> <tr> <td style="padding: 2px;">0x31</td> <td style="padding: 2px;">0x31</td> </tr> </table>		0x31	0x31
	0x31		0x31	
	Sales Message No (2 Bytes) →			
	Sales Message Name (40 Bytes) →			
	Check Sum (3Bytes) →			
ETX (0x03) →				
CR (0x0d) →				
	← ACK (0x06) OR NAK (0x15)			
EOT (0x04)=End of Data →				

7. Price Change

P.C	<p>ENQ (0x05) →</p> <p style="text-align: right;">← ACK (0x06)</p> <p>STX (0x02) →</p> <p>Data Length (3Bytes) →</p> <p>Send ID →</p> <table border="1" style="margin-left: auto; margin-right: auto;"> <tr> <td style="text-align: center;">0x30</td> <td style="text-align: center;">0x30</td> </tr> </table> <p>Group Code (2 Bytes) →</p> <p>PLU No (8 Bytes) →</p> <p>Change Price (8 Bytes) →</p> <p>Check Sum (3Bytes) →</p> <p>ETX (0x03) →</p> <p>CR (0x0d) →</p> <p style="text-align: right;">← ACK (0x06) or NAK (0x15)</p> <p>EOT (0x04)=End of Data →</p>	0x30	0x30	SCALE
0x30	0x30			

8. No PLU (When there is no PLU Data)

P.C	<p>ENQ (0x05) →</p> <p style="text-align: right;">← ACK (0x06)</p> <p>STX (0x02) →</p> <p>Data Length (3Bytes) →</p> <p>Send ID →</p> <table border="1" style="margin-left: auto; margin-right: auto;"> <tr> <td style="text-align: center;">0x31</td> <td style="text-align: center;">0x32</td> </tr> </table> <p>Network Department Code (2 Bytes) →</p> <p>PLU No (8 Bytes) →</p> <p>Check Sum (3Bytes) →</p> <p>ETX (0x03) →</p> <p>CR (0x0d) →</p> <p style="text-align: right;">← ACK (0x06) OR NAK (0x15)</p> <p>EOT (0x04)=End of Data →</p>	0x31	0x32	SCALE
0x31	0x32			

9. ALL PLU Memory Clear.

P.C	ENQ (0x05) →	SCALE		
			← ACK (0x06)	
	STX (0x02) →			
	Data Length (3Bytes) →			
	Send ID →			
	<table border="1" style="display: inline-table;"> <tr> <td style="padding: 2px;">0x31</td> <td style="padding: 2px;">0x33</td> </tr> </table>		0x31	0x33
	0x31		0x33	
	Network Department Code (2 Bytes) →			
	Delete PLU No(0)(8 Bytes) →			
	Check Sum (3Bytes) →			
ETX (0x03) →				
CR (0x0d) →				
	← ACK (0x06) OR NAK (0x15)			
EOT (0x04)=End of Data →				

10. One PLU Memory Clear.

P.C	ENQ (0x05) →	SCALE		
			← ACK (0x06)	
	STX (0x02) →			
	Data Length (3Bytes) →			
	Send ID →			
	<table border="1" style="display: inline-table;"> <tr> <td style="padding: 2px;">0x31</td> <td style="padding: 2px;">0x34</td> </tr> </table>		0x31	0x34
	0x31		0x34	
	Network Department Code (2 Bytes) →			
	Delete PLU No(8 Bytes) →			
	Check Sum (3Bytes) →			
ETX (0x03) →				
CR (0x0d) →				
	← ACK (0x06) OR NAK (0x15)			
EOT (0x04)=End of Data →				

11. Label Data Format.

P.C	ENQ (0x05) → <div style="text-align: right;">← ACK (0x06)</div> STX (0x02) → Data Length(0) (3Bytes) → Send ID → <div style="display: flex; justify-content: center; gap: 10px;"> <div style="border: 1px solid black; padding: 2px;">0x31</div> <div style="border: 1px solid black; padding: 2px;">0x35</div> </div> Total Packet (1 Bytes) → Current Packet(1 Bytes) → Label Data Length (4Bytes) → Label Data (Label Data Length Bytes) → Check Sum (3Bytes) → ETX (0x03) → CR (0x0d) → <div style="text-align: right;">← ACK (0x06) OR NAK (0x15)</div> EOT (0x04)=End of Data →	SCALE
------------	---	--------------

* 1400 bytes of size of data are maximum at data transmission.

* If we are rather big 1400 bytes. We divide the 1400byte and must send(Packet)

Data Length :

0 always must go in the communication of Label data.

Total Packet :

Whole number of Packet to send

ex 0 < Label Data Length < 1400 Total Packet = 1.

1400 < Label Data Length < 2800 Total Packet = 2.

2800 < Label Data Length < 4200 Total Packet = 3.

Current Packet :

Communication is packet number

Label Data Length :

Data total bytes.

12. Receive PLU Data

P.C	<p>ENQ (0x05) →</p> <p style="text-align: right;">← ACK (0x06)</p> <p>STX (0x02) →</p> <p>Data Length (3Bytes) →</p> <p>Send ID →</p> <table border="1" style="margin-left: auto; margin-right: auto;"> <tr> <td style="padding: 2px;">0x31</td> <td style="padding: 2px;">0x36</td> </tr> </table> <p>Network Department (2 Bytes) →</p> <table border="1" style="margin-left: auto; margin-right: auto;"> <tr> <td style="padding: 2px;">0x30</td> <td style="padding: 2px;">0x30</td> </tr> </table> <p>START PLU No (8 Bytes)→</p> <p>END PLU No (8 Bytes)→</p> <p>Check Sum (3Bytes) →</p> <p>ETX (0x03) →</p> <p>CR (0x0d) →</p> <p style="text-align: right;">← ACK (0x06) OR NAK (0x15)</p> <p>EOT (0x04)=End of Data →</p>	0x31	0x36	0x30	0x30	SCALE
0x31	0x36					
0x30	0x30					

12-2. Send PLU Data

P.C	<p style="text-align: right;">← STX (0x02)</p> <p style="text-align: right;">(**)← Data Length (3Bytes)</p> <p style="text-align: right;">← Send ID</p> <table border="1" style="margin-left: auto; margin-right: auto;"> <tr> <td style="padding: 2px;">0x31</td> <td style="padding: 2px;">0x36</td> </tr> </table> <p style="text-align: right;">← Network Department Code (2 Bytes)</p> <p style="text-align: right;">← PLU No (8 Bytes)</p> <p style="text-align: right;">← Unit Price (8 Bytes)</p> <p style="text-align: right;">← Group Code (2 Bytes)</p> <p style="text-align: right;">← Item Code (6 Bytes)</p> <p style="text-align: right;">← Cook By Date (3 Bytes)</p> <p style="text-align: right;">← Shelf Life (3 Bytes)</p> <p style="text-align: right;">← Native Code (3 Bytes)</p> <p style="text-align: right;">← PLU Tare (5 Bytes)</p> <p style="text-align: right;">← PLU Type (1 Bytes)</p> <p style="text-align: right;">← Title Code (1 Bytes)</p> <p style="text-align: right;">← Commodity Name-1 (28 Bytes Char)</p> <p style="text-align: right;">← Commodity Name-2 (28 Bytes Char)</p> <p style="text-align: right;">← Ingredient Line-1 (56 Bytes Char)</p> <p style="text-align: right;">← Ingredient Line-2 (56 Bytes Char)</p> <p style="text-align: right;">← Ingredient Line-3 (56 Bytes Char)</p> <p style="text-align: right;">← Ingredient Line-4 (56 Bytes Char)</p> <p style="text-align: right;">← Ingredient Line-5 (56 Bytes Char)</p> <p style="text-align: right;">← Ingredient Line-6 (56 Bytes Char)</p> <p style="text-align: right;">← Ingredient Line-7 (56 Bytes Char)</p> <p style="text-align: right;">← Ingredient Line-8 (56 Bytes Char)</p> <p style="text-align: right;">← Ingredient Line-9 (56 Bytes Char)</p> <p style="text-align: right;">← Ingredient Line-10 (56 Bytes Char)</p> <p style="text-align: right;">← Check Sum (3Bytes)</p> <p style="text-align: right;">← CR (0x0d)</p> <p style="text-align: right;">← ETX (0x03)</p> <p style="text-align: right;">ACK (0x06) OR NAK (0x15) →</p> <p style="text-align: right;">← EOT (0x04)=End of Data</p>	0x31	0x36	SCALE
0x31	0x36			

13. Close Sock

P.C	ENQ (0x05) →	SCALE			
			← ACK (0x06)		
	STX (0x02) →				
	Data Length (3Bytes) →				
	Send ID →				
			<table border="1" style="display: inline-table;"> <tr> <td style="padding: 2px;">0x31</td> <td style="padding: 2px;">0x38</td> </tr> </table>	0x31	0x38
	0x31		0x38		
	Not use (2 Bytes: Only 0) →				
			<table border="1" style="display: inline-table;"> <tr> <td style="padding: 2px;">0x30</td> <td style="padding: 2px;">0x30</td> </tr> </table>	0x30	0x30
	0x30		0x30		
Check Sum (3Bytes) →					
ETX (0x03) →					
CR (0x0d) →	← ACK (0x06)				

PC close socket after receive ACK and 100ms delay.

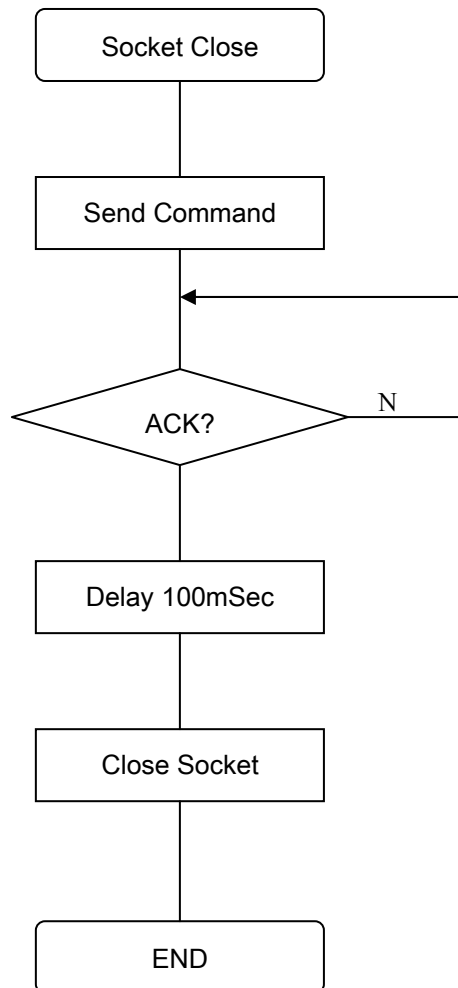

14. Read ROM Version

<p>P.C</p>	<p>ENQ (0x05) →</p> <p style="text-align: right;">← ACK (0x06)</p> <p>STX (0x02) →</p> <p>Data Length (3Bytes) →</p> <p>Send ID →</p> <table border="1" data-bbox="683 383 927 432" style="margin-left: auto; margin-right: auto;"> <tr> <td style="padding: 2px;">0x31</td> <td style="padding: 2px;">0x31</td> </tr> </table> <p>Dummy (8 Byte) →</p> <p>Check Sum (3Bytes) →</p> <p>ETX (0x03) →</p> <p>CR (0x0d) →</p> <p style="text-align: right;">← Version (8 byte)</p> <p>EOT (0x04)=End of Data →</p>	0x31	0x31	<p>SCALE</p>
	0x31	0x31		

Commodity Name-1 (28 Bytes)

If PLU became input to commodity name 2nd, data lengths are 98 Bytes.

PLU No (8 Bytes)	Unit Price (8 Bytes)	...	PLU Type (1 Bytes)	Title Code (1 Bytes)
---------------------	-------------------------	-----	-----------------------	-------------------------

Commodity Name1 (28 Bytes)	Commodity Name2 (28 Bytes)
----------------------------	----------------------------

If PLU became input to Ingredient 1st, data lengths are 154 Bytes.

PLU No (8 Bytes)	Unit Price (8 Bytes)	...	PLU Type (1 Bytes)	Title Code (1 Bytes)
---------------------	-------------------------	-----	-----------------------	-------------------------

Commodity Name1 (28 Bytes)	Commodity Name2 (28 Bytes)	Ingredient 1 st (56 Bytes)
-------------------------------	-------------------------------	--

...

If PLU became input to Ingredient 10th, data lengths are 658 Bytes.

PLU No (8 Bytes)	Unit Price (8 Bytes)	...	PLU Type (1 Bytes)	Title Code (1 Bytes)
---------------------	-------------------------	-----	-----------------------	-------------------------

Commodity Name1 (28 Bytes)	Commodity Name2 (28 Bytes)	Ingredient 1 st (56 Bytes)	...	Ingredient 10 th (56 Bytes)
-------------------------------	-------------------------------	---	-----	--

2. Sales Data information

P.C	<p>ACK (0x06) →</p> <p style="text-align: right;">←ENQ (0x05)</p> <p style="text-align: right;">←STX (0x02)</p> <p style="text-align: right;">←Data Length (3Bytes)</p> <p style="text-align: right;">←Send ID</p> <table border="1" style="margin: auto;"> <tr> <td style="text-align: center;">0x30</td> <td style="text-align: center;">0x30</td> </tr> </table> <p style="text-align: right;">← Scale ID (2 Bytes)</p> <p style="text-align: right;">← Network Department Code (2 Bytes)</p> <p style="text-align: right;">←Date/Time (14 Bytes)</p> <p style="text-align: right;">←PLU NO (8 Bytes)</p> <p style="text-align: right;">←Operator NO (2 Bytes)</p> <p style="text-align: right;">←Type(1 Bytes) (0=Count sale, 1=Weight sale)</p> <p style="text-align: right;">←Weight (5 Bytes)</p> <p style="text-align: right;">←Unit Price (8 Bytes)</p> <p style="text-align: right;">←Total Price (8 Bytes)</p> <p style="text-align: right;">←Check Sum (3Bytes)</p> <p style="text-align: right;">←CR (0x0d)</p> <p style="text-align: right;">←ETX (0x03)</p> <p>ACK (0x06) OR NAK (0x15)→</p> <p style="text-align: right;">← EOT (0x04)=End of Data</p>	0x30	0x30	SCALE
0x30	0x30			

3. PLU transmission request

P.C	<p>ACK (0x06) →</p> <p>← ENQ (0x05)</p> <p>← STX (0x02)</p> <p>← Data Length (3Bytes)</p> <p>← Send ID</p> <table border="1" style="margin: auto;"> <tr> <td style="text-align: center;">0x30</td> <td style="text-align: center;">0x33</td> </tr> </table> <p>← Scale NO (2 Bytes)</p> <p>← Network Department Code (2 Bytes)</p> <p>← Start PLU No (8 Bytes)</p> <p>← End PLU No (8 Bytes)</p> <p>← Check Sum (3Bytes)</p> <p>← CR (0x0d)</p> <p>← ETX (0x03)</p> <p>ACK (0x06) OR NAK (0x15) →</p> <p>← EOT (0x04)=End of Data</p>	0x30	0x33	SCALE
0x30	0x33			

4. Modify Price transmission

P.C	<p>ACK (0x06) →</p> <p>← ENQ (0x05)</p> <p>← STX (0x02)</p> <p>← Data Length (3Bytes)</p> <p>← Send ID</p> <table border="1" style="margin: auto;"> <tr> <td style="text-align: center;">0x30</td> <td style="text-align: center;">0x34</td> </tr> </table> <p>← Scale ID (2 Bytes)</p> <p>← Network Department Code (2 Bytes)</p> <p>← PLU No (8 Bytes)</p> <p>← Price (8 Bytes)</p> <p>← Check Sum (3Bytes)</p> <p>← CR (0x0d)</p> <p>← ETX (0x03)</p> <p>ACK (0x06) OR NAK (0x15) →</p> <p>← EOT (0x04)=End of Data</p>	0x30	0x34	SCALE
0x30	0x34			

5. Returned sale information

